

# 5G STANDARDS WHERE DO WE STAND

*5G INDIA 2019  
26-27 JUNE 2019*

Satish Jamadagni

**Jio**

## 5G STANDARDS – SOME KEY CONCERNS

- Capacity and Coverage concerns
- Backhaul Considerations
- Deployment Flexibility Considerations (Support for SA Deployment Option-6)
- New Service Types (MBMS support, Support for Industry Verticals)
- Automation



## 5G STANDARDS – COVERAGE AND CAPACITY CONCERNS

Moving towards 3GPP Release 17

### Limited Spectrum

- LTE 20MHz (+/- 10Mhz) /per operator TDD band 40
- Indian operators: Per bit pricing least in the world
- Most LTE cell sites near full capacity – operators are exploring Massive MIMO upgrades
- Capacity enhancements at critical for low cost bit delivery

### Coverage

- 3.5 GHz needs to offer coverage levels comparable to LTE
- LMLC Rural scenario
  - Large rural population, sparse villages, Typical Inter-site distance: 6Km -12Km
  - Relook at physical layer design to support at least 12-dB coverage gain

### Backhaul continues to be a limitation in both urban and rural use cases

- Need for IAB/Relays, 60Ghz solutions

**NB-IOT is key for Agri Tech, Smart Cities etc in India - NB-IoT enhancements for capacity / Coverage are critical**



## 5G STANDARDS – BACKHAUL CONCERNS

Moving towards 3GPP Release 17

### WAVEFORM FOR >60GHz NR

Operation beyond 60GHz, the PA efficiency is a major consideration for both downlink and uplink

For the downlink, waveforms other than OFDM are being considered

DFT-S-OFDM is a potential solution to increase the DL PA efficiency

Therefore,  $\pi/2$  BPSK with spectrum shaping proposal is highly suitable and could be considered for beyond 60GHz systems.

Backhaul Coverage: ~6 db additional coverage gain compared to OFDM

# 5G DEPLOYMENT FLEXIBILITY

## 4G and 5G Deployment Options

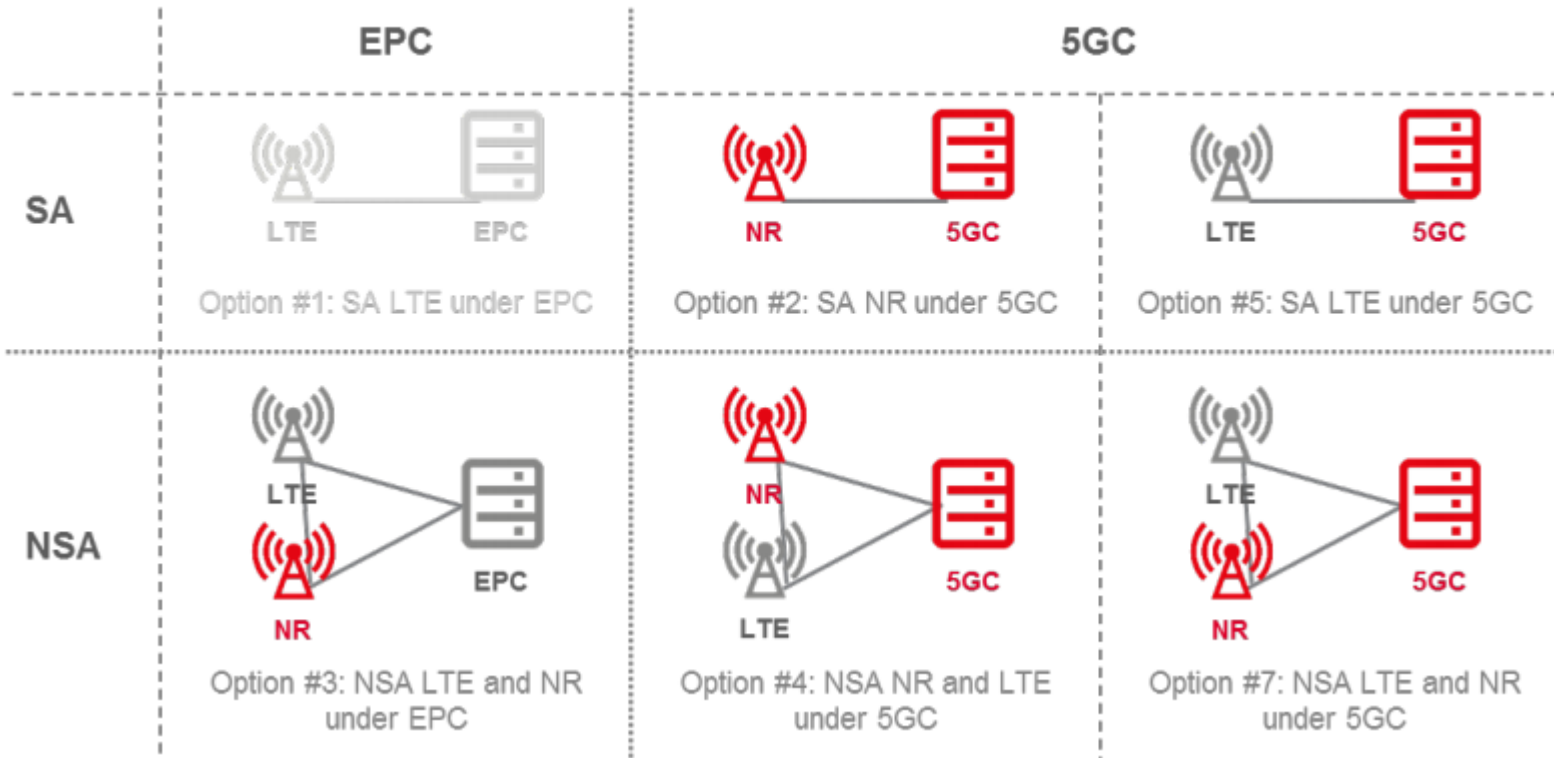



# 5G DEPLOYMENT FLEXIBILITY

## Support for Deployment Option 6

The signaling load in a 5G NR in NSA mode can be quite prohibitive specifically for operators that are facing heavy loads against their cell capacity.

EN DC adds to signaling load on LTE Cells based on the number of 5G RUs in an LTE Cell coverage

KPIs VALUES EXPECTED FOR 5G NETWORKS.

KPI	Use case	Target value
Peak data rate <sup>a</sup>	eMBB	10 Gbps for UL
	eMBB	20 Gbps for DL
User plane latency	eMBB	4 ms for UL and DL
	URLLC	0.5 ms for UL and DL
	URLLC	1 ms for UL and DL
User experienced data rate <sup>a</sup>	eMBB (dense urban)	50 Mbps for UL
	eMBB (dense urban)	100 Mbps for DL
Mobility <sup>b</sup>	High speed vehicular	120 km/h to 500 km/h
	Vehicular	10 km/h to 120 km/h
	Pedestrian	0 km/h to 10 km/h
	Stationary	0 km/h
Mobility interruption time	eMBB and URLLC	0 ms

RRC signaling Load  
due to bursty data



### Stand Alone Deployment Option

To consider an early deployment of the Stand Alone (SA) option, the NG Core is still to mature. The cost considerations are also heavy due to many new core elements. The dependency on the MANO specification derived from the IETF and ETSI specifications along with multiple other gaps as listed below could mean that operators would consider a SA option (involving a fully functional 5GC) **not in the near future**.

1. A single Service Orchestration Manager (SOM) product to support multi-domain service orchestration;  
Centralized policy management and enforcement
2. Dynamic inventory management, to provide real-time visibility into the network and IT
3. Cross-domain Orchestration. Typically, orchestrators focus on their own contained domain—such as content delivery networks (CDNs), mobile backhaul, IP VPNs, and so on. For NFV/SDN to reach its full potential, orchestration will need to break down these silos and happen across these domains. Lack of an “orchestrator of orchestrators” that has an end-to-end view of the network.

The BEST way forward could be “Option 6” which would use a fully functional 5G NR “Radio” catering to both data and signaling independently BUT connected to the EPC core. This could give the best cost advantages and “Early 5G Readiness”. The LTE EPC could be “Virtualized” and moved to a 5G core in time when the 5GC matures.

# 5G Network Architecture

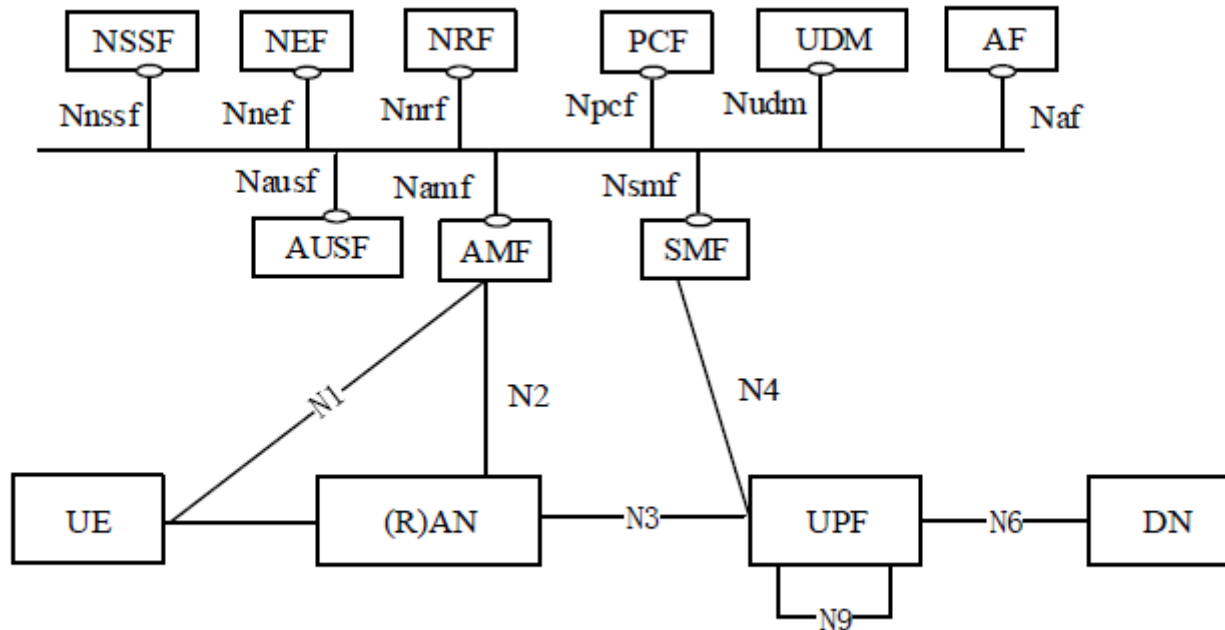

## 5G System architecture

- Network Exposure Function (NEF)
- Network Repository Function (NRF)
- Network Slice Selection Function (NSSF)



# 5G DEPLOYMENT FLEXIBILITY – What is the 5G Core bringing to the table

## MME to AMF, SMF and AUSF

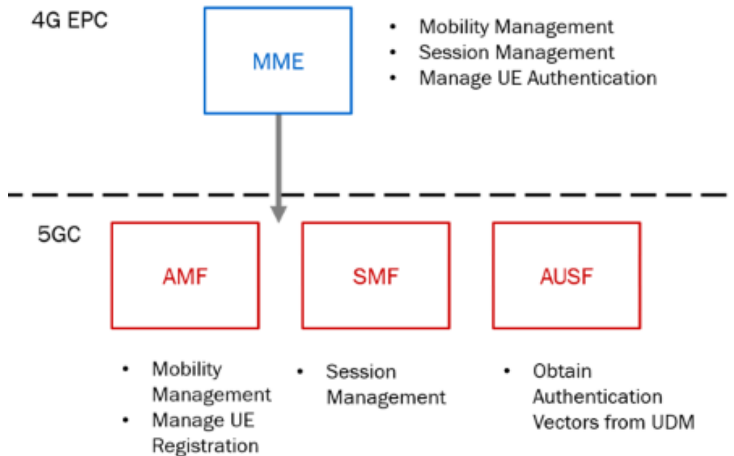

## S-GW and P-GW to SMF, UPF

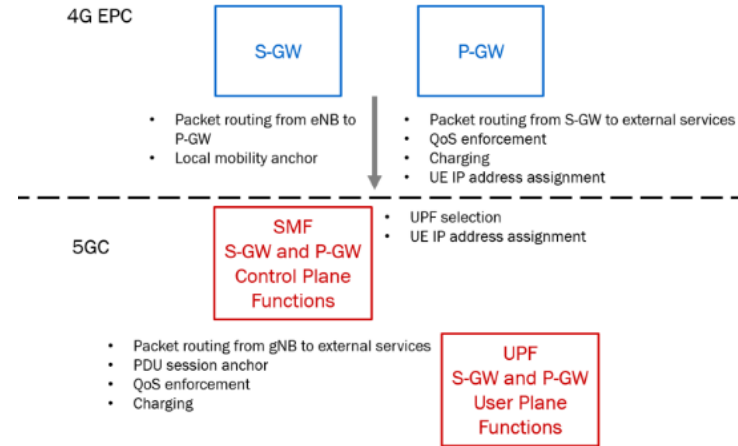

## NOTHING NEW

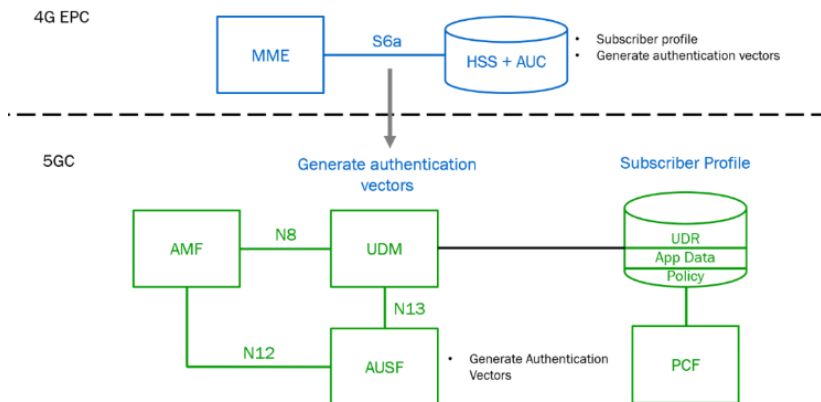

Policy control in 5G is provided by the Policy Control Function (PCF), the same as the 4G PCRF but with a few added capabilities.

Network slicing is a new capability of the 5G network. It allows an operator set up multiple virtual slices of the RAN, core and transport networks to meet specific service requirements.

N3IWF: The Non-3GPP access Inter-Working Function (N3IWF) is similar to the ePDG in the 4G EPC,



# Virtualization and orchestration - Open Source efforts



Too many open source projects out there

Among the main areas that are being developed by the open source groups, the following are still OPEN:

Policy-based resource management, analytics for visibility and orchestration, service verification with regards to security and resiliency.



## ONAP - Open Networking Automation Platform

For NFV deployments to move beyond single-function virtualization to broad-scale NFV architecture will require multivendor interoperability, performance at scale and sophisticated orchestration.

Key for adoption is the integration of virtual functions with operations and business support systems (OSS/BSS).

It is anticipated that ONAP's maturation will take many years meanwhile service providers will need to continue to rely on vendor-specific NFV MANO options. More vendor specific implementations will lead to problems of subsequent migration.

Hypervisors remain popular NFV platform options. Containers are expected to see increased popularity over time -- 2020 and beyond



## 5G STANDARDS – NEW SERVICE TYPES

Moving towards 3GPP Release 17

### MBMS Support

- Specify a NR MBMS numerology to fulfill NR MBMS requirements specified in TR 38.913 and TS 22.261[RAN1]
  - Standalone MBMS on NR and NSA deployments to be considered
- Support MBMS offload mechanisms [RAN3, RAN2]
  - MBMS Signaling channel on LTE, MBMS bearers on NR
  - MBMS Signaling channel on LTE or NR, MBMS bearers on any other Broadcast Standard (ATSC 3.0, DVB-T2.....)

Service as an after thought in 5G NR?

## 5G STANDARDS – NEW SERVICE TYPES

Moving towards 3GPP Release 17

### Support for Vertices

3GPP SA6 is accelerating work on new verticals - SA6 work on vertical specific enablers are targeted towards services like V2X, UAS, Smart Factories.... the Common API Framework (CAPIF) was developed to enable a unified Northbound API framework across 3GPP network functions,

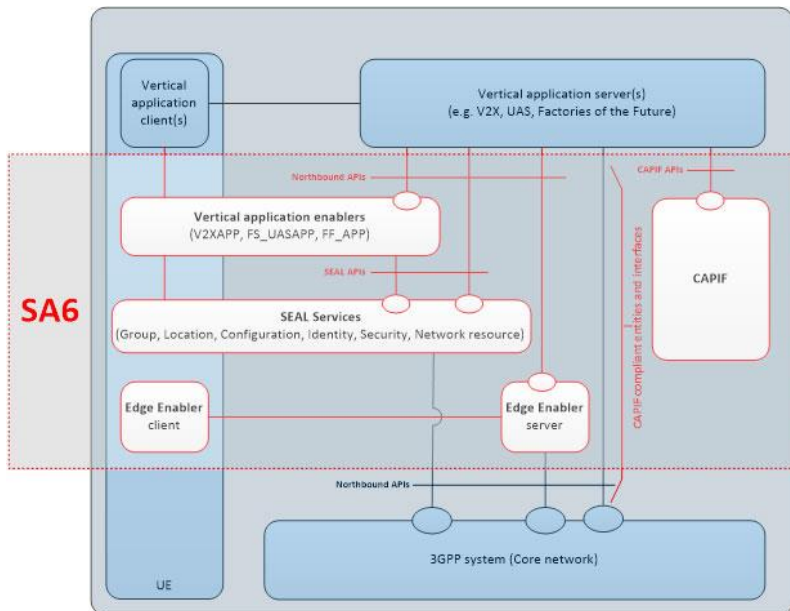

BUT isn't the same thing being achieved by National ICT architectures, IOT Standards

Need for Harmonization

## 5G STANDARDS – AUTOMATION

Beyond 3GPP Release 17

### Enablers For Network Automation

3GPP is working towards Enablers for Network Automation for 5G

The NWDAF (Network Data Analytics Function) as defined in TS 23.503 is used for data collection and data analytics in centralized manner. An NWDAF may be used for analytics for one or more Network Slice.

Such Automation specification cannot be applied across LTE and 5G – lack of interfaces to LTE Core entities.



Does any one believe that LTE  
will go away any time soon







# THANK YOU

